

XS4P18AB120

inductive sensor XS4 M18 - L41mm - PBT - Sn8mm - 12..24VDC - cable 2m

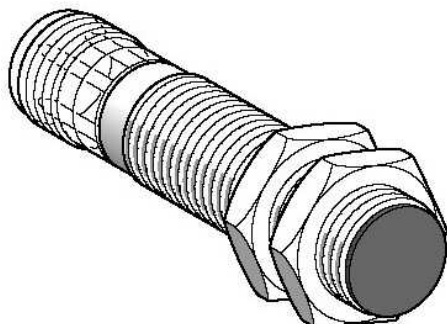

Product availability: Stock - Normally stocked in distribution facility



Main

Commercial Status	Commercialised
Range of product	OsiSense XS
Series name	Application
Sensor type	Inductive proximity sensor
Product specific application	-
Sensor name	XS4
Sensor design	Cylindrical M18
Size	41 mm
Body type	Fixed
Detector flush mounting acceptance	Non flush mountable
Material	Plastic
Type of output signal	Analogue
Wiring technique	2-wire
[Sn] nominal sensing distance	0.31 in (8 mm)
Discrete output function	1 NC
Output circuit type	DC
Analogue output range	4...20 mA
Electrical connection	Cable
Cable length	6.56 ft (2 m)
[Us] rated supply voltage	12...24 V DC
IP degree of protection	IP67 conforming to IEC 60529

Complementary

ISO thread	M18 x 1
Detection face	Frontal
Front material	PPS
Enclosure material	PBT
Operating zone	0.03...0.31 in (0.8...8 mm)
Repeat accuracy	<= 3% of Sr
Linearity error	+/- 2 mA
Cable composition	3 x 0.34 mm ²
Wire insulation material	PvR
Supply voltage limits	10...38 V DC
Switching frequency	<= 500 Hz
Current consumption	4 mA (no-load)
Output current drift	<= 10 %
Marking	CE
Threaded length	1.02 in (26 mm)
Height	0.71 in (18 mm)
Length	1.61 in (41 mm)
Product weight	0.18 lb(US) (0.08 kg)

The information provided in this documentation contains general descriptions and/or technical characteristics of the performance of the products contained herein. This documentation is not intended as a substitute for and is not to be used for determining suitability or reliability of these products for specific user applications. It is the duty of any such user or integrator to perform the appropriate and complete risk analysis, evaluation and testing of the products with respect to the relevant specific application or use thereof. Neither Schneider Electric Industries SAS nor any of its affiliates or subsidiaries shall be responsible or liable for misuse of the information contained herein.

Environment

Product certifications	CSA UL
Ambient air temperature for operation	-13...158 °F (-25...70 °C)

Ordering and shipping details

Category	22486 - SENSORS, PROXIMITY
Discount Schedule	DS2
GTIN	00785901721826
Nbr. of units in pkg.	1
Package weight(Lbs)	0.21
Product availability	Stock - Normally stocked in distribution facility
Returnability	Y
Country of origin	FR

Offer Sustainability

Sustainable offer status	Green Premium product
RoHS	Compliant - since 0811 - Schneider Electric declaration of conformity
REACH	Reference not containing SVHC above the threshold
Product environmental profile	Available Download Product Environmental
Product end of life instructions	Available Download End Of Life Manual

Contractual warranty

Period	18 months
--------	-----------